

## POWER RATING

Production tolerance :  $\pm 3\%$

MODEL	CONDITIONS	POWER	rpm	Base Engine
4V158TIH	HEAVY DUTY	390kW (530PS)	1,800	D2848LB
4V158TIM	MEDIUM DUTY	441kW (600PS)	2,100	
4V158TIL	LIGHT DUTY	588kW (800PS)	2,300	

**Note : 1)** No reduction in rating for intake air temperature is up to 45 °C (318K) and sea water temperature is up to 32 °C (305K) , relative humidity is up to 60 % all data are based on operation to ISO 3046.

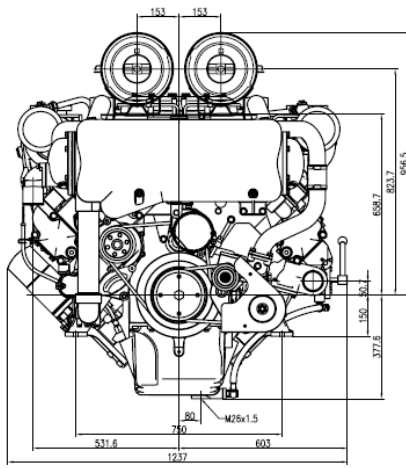

(Heavy Duty)

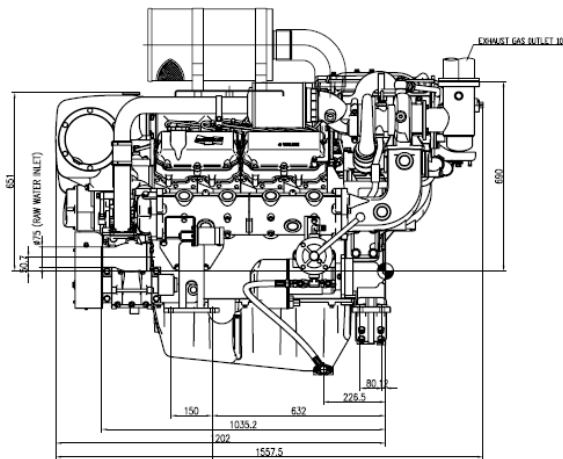

(Medium Duty)

(Light Duty)

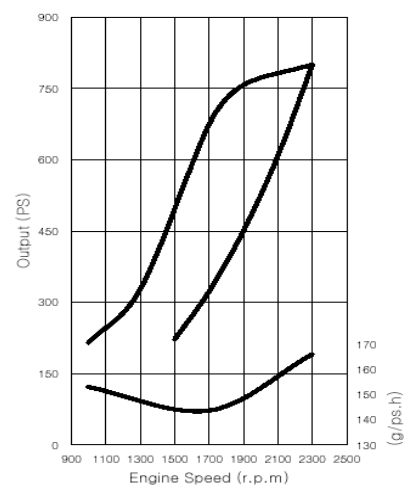
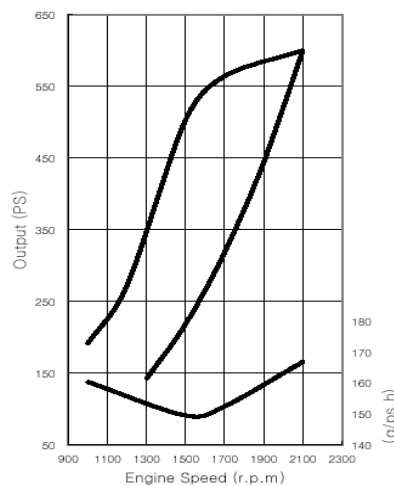

- **Heavy Duty** : Operation hours are unlimited per year, at average load is up to 90 % , at full load is up to 80 %  
Typical gearbox ratio: 2.5 ~ 6  
(Fishing trawler, Tug boat, Pushing vessel, Cargo boat, Freighter, Ferry)
- **Medium Duty** : Operation hours are up to 3,000 per year, at average load is up to 70 %  
At full load is (up to 30 % / 4hrs per 12 hour operation period).  
Typical gearbox ratio: 2 ~ 3.5  
(Fishing boat, Pilot boat, Escort boat, Passenger boat, Ferry, Cruising vessel)
- **Light Duty** : Operation hours are up to 1,000 per year, at average load is up to 50 %  
At full load is (up to 20 % / 2hrs per 12 hour operation period)  
Typical gearbox ratio: 1 ~ 2.5  
(Light weight fishing boat, Yacht, Coastguard boat, Fast boat, Fire pump, Navy, Bow thruster)

Engine Specification			4V158TIH	4V158TIM	4V158TIL
Model	Units				
Engine type		4 valve, 4 cycle, V type, direct- injection, water cooled with wet turbo charger & inter-cooler			
Rating output (B.H.P)	kW(PS)/rpm		390(530)/1,800	441(600)/2,100	588(800)/2,300
Displacement	cc	14,618			
Cylinder number - bore( $\phi$ ) x stroke	mm	8 - $\phi$ 128 x 142			
Valve clearance at cold	In / Ex	mm	0.40 / 0.50		
Low idling rpm	rpm	725 $\pm$ 25			
No load max. rpm	rpm		below 2,070	below 2,415	below 2,645
Mean effective pressure	kg/cm <sup>2</sup>		18.1	17.6	21.4
Mean piston speed	m/sec.		8.52	9.94	10.89
Compression ratio			14.3 : 1	14.3:1	14.3:1
Firing order		1 - 5 - 7 - 2 - 6 - 3 - 4 - 8			
Governor type of injection pump		Mechanical variable speed (R.Q.V)			
Fuel consumption	g / PS.h		153	167	166
	Lit / h		97	120	159
Starting system		Electric Starting by starter motor			
Starter motor capacity	V - kW		24 - 6.6		
Alternator capacity	V - A		24 - 50		
Battery	V - Ah		24 - 200		
Cooling system		Indirect sea water cooling with heat exchanger			
Cooling water capacity	Max. / Min.	lit.	94 / 83		
Fresh water pump type		Centrifugal type, driven by belt			
Sea water pump type		Bronze impeller type driven by belt			
Lubricating oil (Engine)	pan capacity	lit.	Max : 31, Min : 25 (Engine total : 35)		
	pressure	kg/cm <sup>2</sup>	Full : 3.5, Idle : 1.2		
Direction of revolution	crankshaft		Counter clockwise viewed from stern side		
Engine Size ( L x W x H )	mm	1,558 x 1,237 x 1,334			
Engine dry weight	kg		1,540	1,540	1,580

psi = kg/cm<sup>2</sup> x 14.22  
 lb/ft. = N.m x 0.737  
 kW = 0.2388 kcal/s

lb= kg x 2.205  
 lb/PS.h = g/kW.h x 0.00162  
 cfm = m<sup>3</sup>/min x 35.3

hp = PS x 0.98635  
 U.S gal. = liter x 0.264

**Head office**  
 7-11, Hwasu-Dong, Dong-Gu, Incheon, Korea  
**TEL : 82-32-211-2246, 2248 FAX : 82-32-761-2759**  
**Seoul Office**  
 Doosan Infracore Co. Ltd.,  
 21st Floor, Doosan Tower, 18-12, Euljiro 6-ga, Jung-gu,  
 Seoul, Korea.  
**TEL : 82-2-3398-8400 FAX : 82-2-3398-8509**  
 Web site : [www.doosaninfracore.com](http://www.doosaninfracore.com)

※ Specifications are subject to change without prior notice.